

BRIAN JAMES TRAILERS

» Connected to you



CARGO TIPPER2 OPERATOR BENEFITS

UNITED KINGDOM

CARGO TIPPER 2



CARGO TIPPER2 THE PERFECT BALANCE

5 5 YEAR
CHASSIS
WARRANTY



Tipper trailers joined the Brian James Trailers range in 2009 with the first generation proving our unique solutions to many of the long standing design challenges.

Tipper2 had to be incredibly robust, yet able to carry and tip meaningful loads. It had to be high enough for site access and tipping ability, yet possess a low centre of gravity for best towing and loading performance. We feel that nearly 40 years of experience have been employed wisely in devising unique and successful solutions to these challenges.

Expect the best. **Tipper2** will provide it.



CARGO TIPPER 2

CARGO TIPPER2

The Perfect Balance

Our objective was simple. Make a tougher, safer **Tipper** trailer with class leading technologies employed where appropriate to reduce weight and enhance operation standards. In every meaningful way the **CarGO Tipper2** has succeeded.

No other product in the sector can match **Tipper2**'s unique combination of value, features and quality. Unrivalled safety systems such as an audible warning when the bed lowers will instantly appeal to any health and safety conscious operator. The 270° hinged doors combined with a very steep tip angle offer the cleanest exit for heavy or bulky loads and minimises operator risk.

But making trailers this capable doesn't mean making them heavy; by choosing high grade steels and aluminium our engineers have made the strong and light chassis of the **CarGO Tipper** even stronger and lighter, which means the new **CarGO Tipper2** benefits from even greater load carrying and efficiency.



- **New deck construction** with no fasteners in vulnerable positions, making tipping, cleaning and shovelling easy.
- **Flush internal fixtures** ensuring no opportunities for materials to become trapped and retained once tipped.



- **Side hinged rear doors** New hinge and latch mechanism is well engineered to provide an easy and reliable operation.



- **Corner and centre posts** can be fitted and removed in seconds.



- Tough, durable and low-friction **bed surface** combined with a high tilt angle of nearly 60° means that materials will conveniently discharge.



- **Reinforced, bonded phenol ply with steel lined deck** A brand new aluminium extrusion is a unique solution to the challenge of fixing the heavy duty deck into the chassis. Bonding the outer 2mm steel deck liner to the 18mm industrial grade phenol ply creates a very tough and durable load bearing surface, with the added benefit of easily discharging the load during tip operation.



- **Heavy duty drop sides** Features 2mm steel material and distinctive yellow body work, bringing high levels of visibility and safety. Headboard fully removable.

- **Integral tie-down points** inside the bed offer a significant benefit to any operator carrying machinery. Experience the convenience of multiple points, all as standard. Load loss is prevented with a spring steel flap.



MULTIPLE ANCHOR POINTS

- **Safety stand** for maintenance and repair.

- **Rope hooks and eyes** along both sides, under deck.



- **New rear lighting** arrangement with CarGO Connect lighting kit.

- **Upgrade to full LED lighting**
Replace bulbed rear lamps with LED technology. Super bright and extremely durable.

- **Integral coupling head lock**



- **Storage box** is ideal for keeping remote control, jump lead set and straps conveniently to hand.



- **Spare wheel** stored in rear under tray, released from the rear without having to tip the load.

- **Auto-retract heavy duty jockey wheel**
Best ground clearance from retracting wheel lessens chance of jockey wheel damage. High capacity lift mechanism.



● Standard. ○ Optional at extra cost.

CARGO TIPPER 2

OPTIONS

Tip the balance in your favour

If you need it, it's fitted. If you want it, it's here.

In designing the ultimate tipper trailer we set out to create a full working package, exactly what is needed to maximise the utility of the CarGO Tipper2.

For specific operations we designed a variety of suitable options, all detailed across the following pages.



○ **High panelled side extension kit** enabling the transport of bulkier loads. Light weight, yet robust panels can be individually removed, along with the quick release retaining posts. This enhanced functionality makes **Tipper2** easily configurable.



○ **CarGO Connect ramps**
Trailer equipped with ramp rack as standard.

Choose:
1.8m ramps for general loading purposes or
2.3m ramps for lowest possible loading angle.

○ **Rear stands** with kick down action provide support for loading.



13" wheel

12" wheel

*Unladen deck height

○ Choice of 12" (3,500 kg) and 13" (2,700 kg) wheels / tyres
Smaller capacity trailers can be upgraded to 12" Heavy Duty wheels / tyres, lowering deck by 25mm.

○ Upgrade to full LED lighting
Replace bulbed rear lamps with LED technology. Super bright and extremely durable.

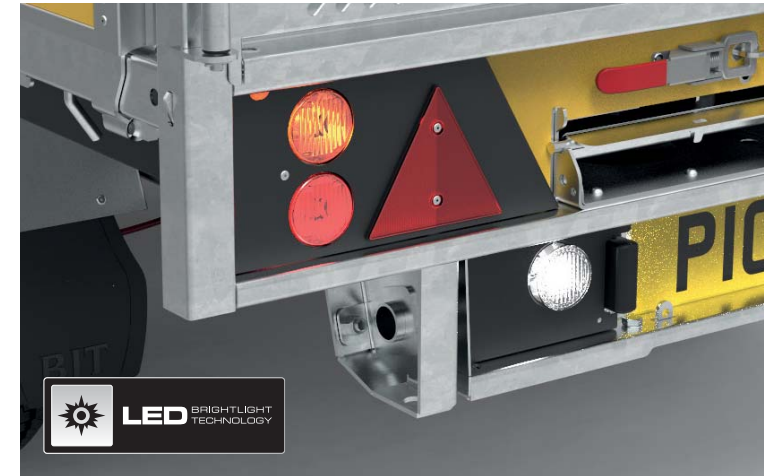

○ Ladder rack is a convenient frame providing the ability to carry ladders and materials longer than the trailer bed.



○ Electric winch option with roller guides.

CARGO TIPPER 2

CARGO TIPPER2

FULLY EQUIPPED

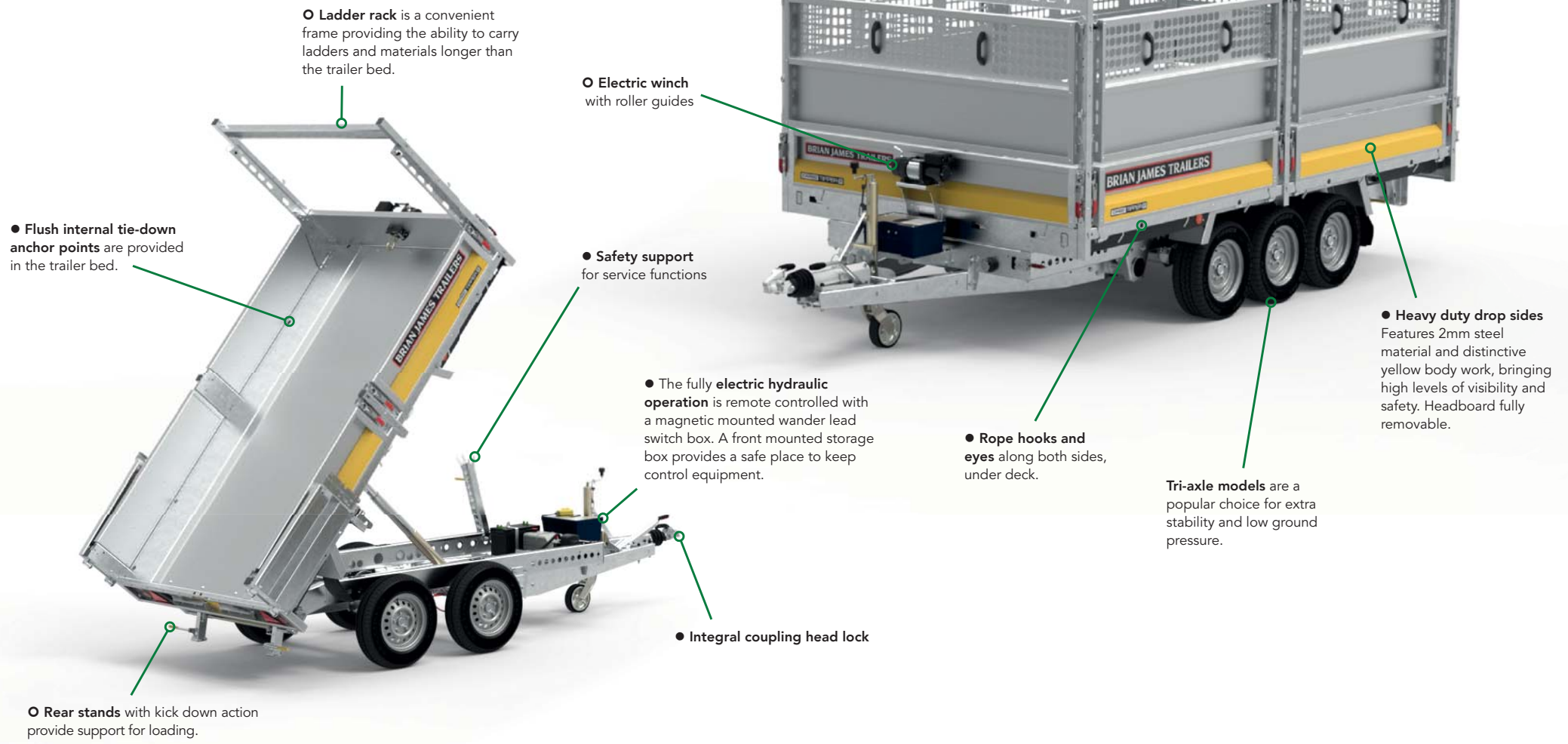

○ **Ladder rack** is a convenient frame providing the ability to carry ladders and materials longer than the trailer bed.

● **Flush internal tie-down anchor points** are provided in the trailer bed.

○ **Electric winch** with roller guides

● **Safety support** for service functions

● The fully **electric hydraulic operation** is remote controlled with a magnetic mounted wander lead switch box. A front mounted storage box provides a safe place to keep control equipment.

● **Integral coupling head lock**

○ **High panelled side extension kit** extends the trailer height enabling the transport of bulkier loads.

● **Rope hooks and eyes** along both sides, under deck.

● **Heavy duty drop sides**
Features 2mm steel material and distinctive yellow body work, bringing high levels of visibility and safety. Headboard fully removable.

Tri-axle models are a popular choice for extra stability and low ground pressure.

○ **Rear stands** with kick down action provide support for loading.

TECHNICAL INFORMATION.

STANDARD					
LOAD BED LENGTH m A	2.70	3.10		3.60	
CAPACITY					
Gross kg	2,700	2,700	3,500	3,500	3,500
Load kg	1,970	1,920	2,570	2,520	2,480
Unladen trailer weight kg	730	780	930	980	1,020
DIMENSIONS					
Internal bed width m B	1.60	1.60	1.60	1.84	1.84
Overall trailer width m C	1.71	1.71	1.71	1.95	1.95
Overall trailer length m D	4.12	4.52	4.52	5.02	5.02
Bed load height m	**0.71	**0.71	0.685	0.685	0.685
Towball height (loaded, centre of towball) m	**0.44	**0.44	0.415	0.415	0.415
RUNNING GEAR					
Axles	2	2	2	2	3
Wheel / Tyre size	13" (165 C)	13" (165 C)	12" (195/60)	12" (195/60)	12" (195/60)
Spare wheel	●	●	●	●	●
HYDRAULICS					
Hydraulic rams	1	1	1	1	1
12v electric hydraulic pump	●	●	●	●	●
PRODUCTS					
Product code	525-1111	525-2111	525-2121	525-3221	525-3222
OPTIONS					
WHEEL OPTION					
Upgrade from 165R13 C tyre to 195/60R12 HD tyre. Applies to 2,700kg gross capacity models only	○	○			-
BED BASE					
Steel lined bed with ply wood base, bonded and located by a fastener free HD extrusion	●	●			●
REAR LOADING					
High grip punched ramps 1.80m	○	○			○
High grip punched ramps 2.35m	○	○			○
Rear kick down support legs	○	○			○
DROP SIDES					
Steel drop sides 0.30m with side hinged rear doors	●	●			●
SIDE OPTIONS					
Side extensions, 0.74m additional height sides (removable). Lower half of side extension height is solid panel, top half is punched grill	○	○			○
Ladder rack - suitable for trailers without side extensions fitted	○	○			○
Ladder rack - suitable for trailers with side extensions fitted	○	○			○
LIGHTING					
LED lighting, full rear lighting kit, multi-voltage	○	○			○
WINCH					
Electric Winch Kit, no Power System	○	○			○
Power pack, portable, for electric winch	○	○			○
LOADING, AXLES, WHEELS AND SECURITY					
Tie-down anchor points - sealed (internal)	8 points	8 points			8 points
Tie-down straps x 4 – 4,000 DaN heavy duty	○	○			○
Wheels-Safety kit – torque wrench + digital tyre pressure gauge	○	○			○
Tyre pressure monitoring system – TPMS by TyrePal in-car monitor with external sensors	○	○			○
Cast steel coupling head with integral high security lock	●	●			●
Datatag – Security identification system	○	○			○
Tracker – Anti theft device. By SureTrack. Full time monitoring 24/7. Location of asset + recovery service. Thatcham approved. Sold secure approved. Yearly monitoring fee £90. Year 1 incl.	○	○			○
7 pin socket to 13 pin plug adapter	○	○			○

● Standard. ○ Optional at extra cost.

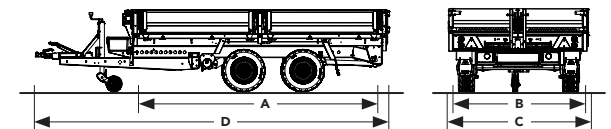

CARGO TIPPER 2

QUALITY

Brian James Trailers are manufacturers of class leading trailers, since 1979. When you buy a Brian James Trailer you can be absolutely certain that it is designed and constructed to the highest possible standards. Our Engineers combine top-quality craftsmanship with the best materials and first-class presentation. Light but strong, our trailers are crafted to enhance safety, efficiency and durability.

5 Year Chassis Warranty

This Brian James Trailer is provided to you with a non-transferable manufacturers warranty covering the integrity of the chassis for a period of 5 years from the date of first registration.

We warrant that under normal use, outside of accident damage or misuse (meaning driven across unsuitable territory or being overloaded) the chassis will not fatigue or fail to be able to perform its intended duties safely.

Any repair or rectification as a result of a claim under this warranty will be at Brian James Trailers cost and be carried out either at a Brian James Trailers main dealer or at the factory HQ in Daventry, UK, at the discretion of Brian James Trailers Ltd. A repair may involve removal of the original galvanised surface finish, for which we will not be liable to reinstate to its original state.

Brian James Trailers will not be liable for any consequential loss in connection with a claim on this warranty, including recovery fees or transport to or from the place of final repair.

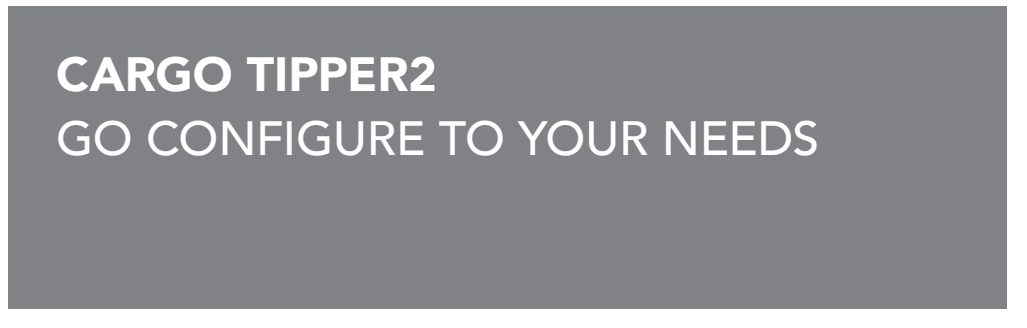
A graphic featuring a large white number '5' on a red square background, followed by the text '5 YEAR CHASSIS WARRANTY' in white capital letters on a black rectangular background.A dark grey rectangular box with a white border containing the text 'CARGO TIPPER2' and 'GO CONFIGURE TO YOUR NEEDS' in white capital letters.



BRIAN JAMES TRAILERS

» Connected to you

NOTES

Specifications are subject to change without notice.
Illustrations and photography may depict optional
equipment.

www.brianjames.co.uk

© BRIAN JAMES TRAILERS LIMITED.
Printed in the UK.

Edition CGTIP22018_Q1_1

Brian James Trailers Limited.
Sopwith Way, Drayton Fields Industrial Estate
Daventry, Northampton, NN11 8PB

T + 44 (0)1327 308 833

Brian James Trailers are available by contacting our sales team as well as
through an extensive network of official dealers throughout the country.

For more information please call or visit our website.

www.brianjames.co.uk

Dealer information.

